

On-site wastewater treatment systems

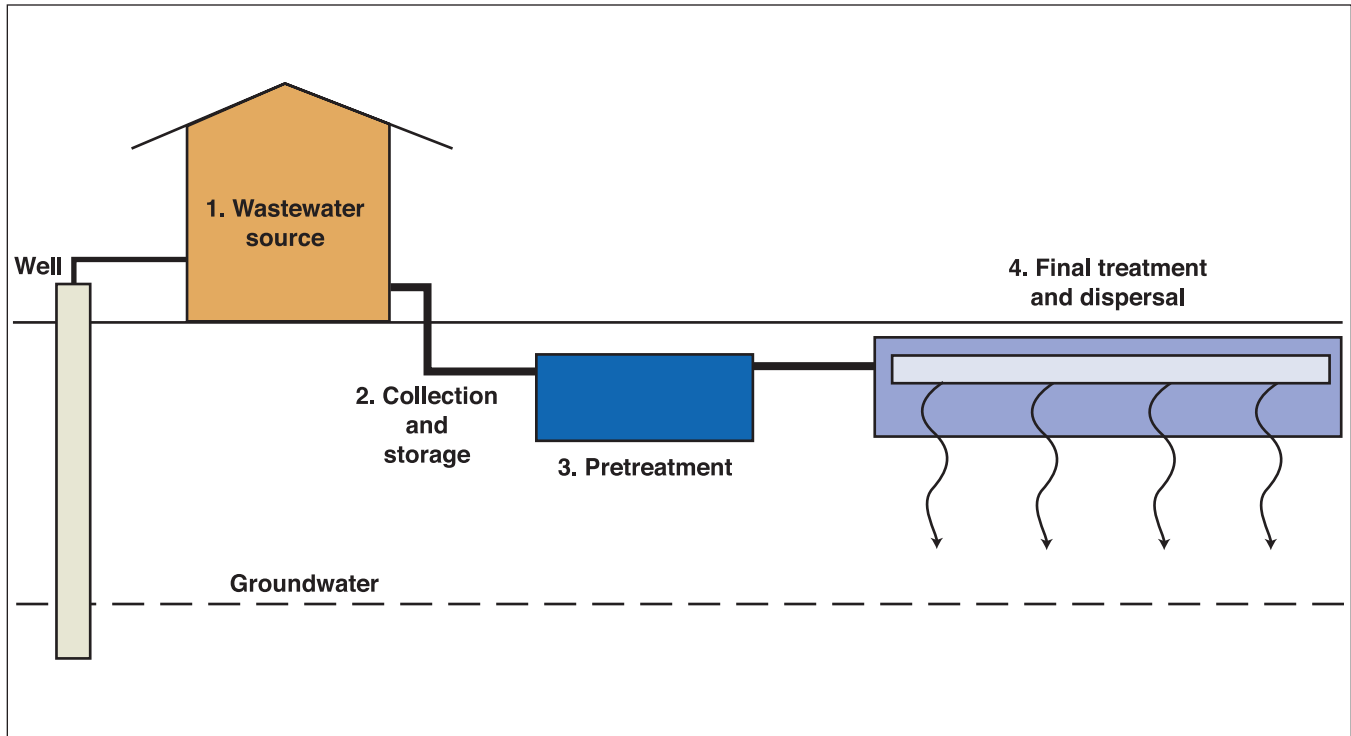

Figure 1: Components of an on-site wastewater treatment system.

Understanding and Maintaining your Septic System

Bruce J. Lesikar, Justin Mechell and Rachel Alexander

Professor and Extension Program Leader for Biological and Agricultural Engineering,
Extension Assistant,
Texas Water Resources Institute Research Assistant,
The Texas A&M University System

Proper operation and maintenance of your wastewater treatment system is critical for its performance. Taking proper care of your system also

- ✓ protects the health of the people living on and near your property,
- ✓ helps safeguard your property values, and
- ✓ helps preserve the quality of groundwater and prevents your sewage from degrading nearby waterways.

To understand how to operate and maintain on-site wastewater treatment systems, you should know how they work and what factors affect them. Figure 1 illustrates the four components of an on-site wastewater treatment system: wastewater source; collection and storage; pretreatment components; and final treatment and dispersal components.

Wastewater source

The wastewater source is the domestic wastewater from homes, schools or businesses that the treatment system serves. The constituents and strength of wastewater, which is 99.9 percent water, can vary by source. Domestic wastewater is water discharged from plumbing fixtures, appliances, toilets, bath, laundry and dishwashers. Owners of on-site wastewater treatment systems should understand that anything they put in their sinks or drains

may pass through their system and into their groundwater and surface water supplies.

Collection and storage

The collection component of a residential system is generally a solid, rigid pipe that collects wastewater from plumbing fixtures and appliances. This pipe, laid at a downward slope of no less than 1 percent ($\frac{1}{8}$ inch drop per foot of pipe), exits the structure and extends to the pretreatment component.

Some sites may have alternative collection systems. These systems may have pump tanks to collect the waste and subsequent lines to transport it to the pretreatment components.

Pretreatment components

Pretreatment components remove many of the contaminants from the wastewater to prepare it for final treatment and dispersal into the environment. Contaminants in the wastewater include harmful bacteria that can cause illness, as well as nitrogen and phosphorous that can stimulate algae growth in water bodies. The level of treatment is selected to match the receiving environment and the intended use of the effluent. The quantity of contaminants must be reduced to a level the soil can accept and treat.

Wastewater pretreatment components include septic tanks, trash tanks, grease traps and processing tanks. Aerobic treatment units, media filters and constructed wetlands are advanced pretreatment components. Homeowners have several options when selecting a system for pretreating wastewater before it is dispersed to the environment.

If your home has more than two showers, a multi-head shower, a whirlpool tub or multiple laundry rooms, or if you generate

lots of wastewater in other ways, you will probably need to install a flow equalization tank. This tank collects wastewater and controls its flow to the pretreatment component, which allows the on-site wastewater treatment system to accept and treat wastewater as it is generated. Without a flow equalization tank, you must modify your lifestyle to match the capacity of the treatment system.

Final treatment and dispersal components

Final treatment and dispersal components are the last step in removing contaminants and dispersing the treated wastewater into the environment. Several options help with distributing wastewater in soil.

Gravity flow systems are the most widely used and least expensive, and they require the least amount of operation and maintenance.

Pressurized distribution methods overcome various site limitations. Low-pressure, subsurface drip and spray dispersal systems are designed to function in difficult areas. Because they are pressurized, they evenly distribute wastewater. Such systems also facilitate the reuse of wastewater in the landscape. These advantages, however, increase the operation and maintenance requirements.

System maintenance

On-site wastewater treatment systems come in many types and sizes. When a house is being planned, the size of its on-site wastewater treatment system is based on the following:

- ✓ Number of bedrooms and square footage of the house
- ✓ Whether water-conserving fixtures will be used
- ✓ Overall site and soil considerations

The most appropriate system is one that will handle the greatest volume and strength (concentration of contaminants) of wastewater for that size of house.

Your water use habits affect how well your wastewater treatment system works. If you use more water than average for the size of your house, your system can be overloaded with water and may fail. If you want to be able to use more water than average, you may need to install a larger than minimum size system.

Your wastewater will be stronger than average if you use a garbage disposal or operate a bakery or daycare facility at home. The wastewater may need additional treatment (e.g., with an aerobic treatment unit, media filter or trickling filter) to bring it back to an average strength or remove most of the contaminants.

The site itself is also a factor. An on-site wastewater treatment system is a no-discharge system, which means that the wastewater must stay on the property where it is generated. All contaminants must be removed from the wastewater before it moves through the soil to groundwater.

The site for your system must have adequate soil to allow for the proper distribution and subsequent dispersal of effluent from your system. If you have poor or shallow soil, a conventional wastewater treatment system will not adequately treat the wastewater. This often occurs with sites that have shallow soils located over fractured rock, Karst limestone or gravelly sand. In this case, your wastewater needs additional treatment before it is applied to the soil. If the wastewater is not treated adequately before it reaches groundwater, your water well can become contaminated.

It is best to follow the maintenance instructions for your system. The following general tips can also help you keep your on-site waste-

water treatment system operating efficiently and trouble-free.

Wastewater source

- ✓ Do not treat an on-site wastewater treatment system as if it were a normal centralized sewer system. Items flushed down the toilet do not disappear. They must be treated by the on-site wastewater treatment system.
- ✓ Leaking toilets and dripping faucets should be fixed immediately. If such problems persist, your wastewater treatment system could be hydraulically overloaded.
- ✓ Do not use in-sink garbage grinders excessively or discard too much grease. Garbage grinders can cause sludge or scum to build up rapidly. This makes it necessary to clean the septic system more frequently and might cause it to fail because the wastewater is too strong for the system to handle.
- ✓ Do not dispose of cleaning tissues, cigarette butts, diapers or other trash in the toilet. This wastes water and loads too many solids into the treatment system.
- ✓ Soaps, detergents, bleaches and other household cleaning materials seldomly affect the operation of the system. However, use them in moderation. Excessive use of cleaning materials, disinfecting or antimicrobial soaps and detergents, or using continuous disinfectants in the toilet bowl, may leave wastewater untreated by killing the microbes in the on-site wastewater treatment system.
- ✓ Excessive wastewater flows can overload the on-site wastewater treatment system. If you wash all your clothes on one day, you could overload the soil treatment area. This causes water to

pond on the ground surface. You could also flush water through the system, which can carry solids through the pretreatment component.

Plumbing and electrical considerations

- ✓ If you have a water softener, consider plumbing the flush-water around the pretreatment component. Send it directly to the final treatment and dispersal component of your on-site wastewater treatment system.
- ✓ Consider plumbing the condensate drain from an air conditioning unit or commercial ice maker to a graywater system rather than to the on-site wastewater treatment system. This extra water can overload the system.
- ✓ Do not intentionally turn off electrical power to an on-site wastewater treatment system that has mechanical components or alarms. For example, do not turn off the power when away on vacation. Sewage that collects when the power is off has not been treated and may be dispersed when power is restarted.

Pretreatment, final treatment and dispersal

- ✓ Natural bacteria in the wastewater decompose the waste. Chemical additives are not necessary for a septic tank to operate. Some additives may even harm the tank's operation. Remember that the septic tank is supposed to collect solids. If you flush solids out of the tank and into the final treatment and dispersal component by adding chemicals, the solids will plug the soil. Then you'll have to replace the soil treatment

component, usually the most expensive part of a system.

- ✓ Have the septic tank cleaned before sludge or scum accumulates to the bottom of the tank's outlet device (about every 2 to 3 years). If too much sludge accumulates, solids will leave the tank with the liquid and possibly clog the soil. Sewage will then surface or back up into the house through the plumbing fixtures.
- ✓ Do not build driveways, storage buildings or other structures over the pretreatment or final treatment and dispersal components. These solid surfaces prevent access to the system for maintenance, reduce the ability of water to evaporate from the soil and restrict air movement into the soil.
- ✓ Do not drive heavy equipment over the components of a wastewater treatment system. The equipment can crush them. The components are designed to support the soil over the top of the system—not equipment driving over it.
- ✓ Maintain a grass cover over the final treatment and dispersal component. Plant warm-season grasses that use more water and over-seed with cool-season grasses during the winter. Grasses remove a significant portion of the water from a system, and the grass cover must be maintained. Trees also remove water and can be planted around the system perimeter. However, roots from trees planted too close to the soil treatment area can clog distribution pipes.
- ✓ Divert any rainwater running off driveways, the roof and other hard surfaces away from the soil treatment area of the final

treatment and dispersal component. The soil treatment area is designed to manage a specific amount of water. Rainwater could fill the system, leaving no room for wastewater. Design landscaping to carry runoff water around the soil treatment area.

Health considerations

- ✓ Maintain the disinfection component of your system. Add the appropriate chlorine product to chlorinators. Replace the UV lamp, as necessary, in UV disinfection systems.
- ✓ Do not come into contact with the liquid from the on-site wastewater treatment system. Even wastewater that has been through a disinfection component may contain pathogens that could make you sick. Some pathogens are resistant to chlorine disinfection.
- ✓ If your system malfunctions or wastewater seeps or ponds on the land surface, immediately seek professional assistance from a licensed wastewater practitioner to eliminate the health hazard.

You are responsible for maintaining your system. You may wish to hire a professional to make sure your system continues to function properly. Having a service contract with an expert on the operation and maintenance of on-site wastewater treatment technologies is a sound and economical approach to properly maintaining and extending the life of your system.

When a professional is making regular service visits, problems are usually detected before they can cause your system to malfunction. Early detection makes it possible to take remedial action before a system becomes a health hazard to you or the public, harms the environment, or becomes a legal liability. Repair all problems quickly. (Common repairs are replacing the air compressor, pumps and spray heads and pumping the tank.) Failure to take care of problems when they occur can cause other parts of the system to fail. A system with one malfunctioning part is a malfunctioning system.

Some localities have regulations that require a certain amount of system management. Even if they are not required in your area, routine inspection and proper system maintenance will ensure that on-

site wastewater treatment systems will continue to be a permanent and effective part of our wastewater treatment infrastructure.

For more information

The selection of an on-site wastewater treatment system should be based on your local conditions. Contact your local permitting authority for information about appropriate technologies in your area. A wastewater professional can also provide information on technologies used in your area.

Additional information can be obtained by visiting the following Web sites:

Texas Commission on Environmental Quality
<http://www.tceq.state.tx.us/>

Texas AgriLife Extension Service
<http://texaswater.tamu.edu/>

Department of State Health Services
<http://www.dshs.state.tx.us/>

Acknowledgments

Guidance and assistance was provided by the Texas Groundwater Protection Committee and the Texas Commission on Environmental Quality. The effort was partially funded by the U. S. Environmental Protection Agency.

Produced by AgriLife Communications and Marketing, The Texas A&M System
Extension publications can be found on the Web at: <http://AgriLifebookstore.org>

Visit the Texas AgriLife Extension Service at <http://texasextension.tamu.edu>

Educational programs of the Texas AgriLife Extension Service are open to all people without regard to race, color, sex, disability, religion, age, or national origin.

Issued in furtherance of Cooperative Extension Work in Agriculture and Home Economics, Acts of Congress of May 8, 1914, as amended, and June 30, 1914, in cooperation with the United States Department of Agriculture. Edward G. Smith, Director, Texas AgriLife Extension Service, Texas A&M System.
2M, Reprint